

Basic shape 1

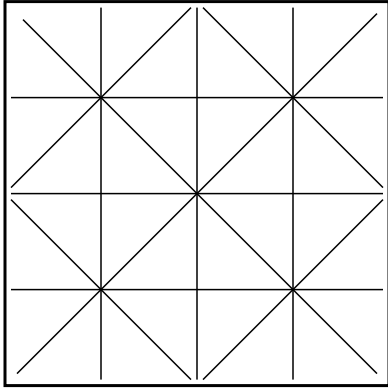

1

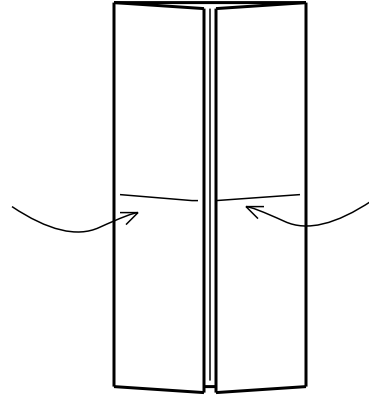

2

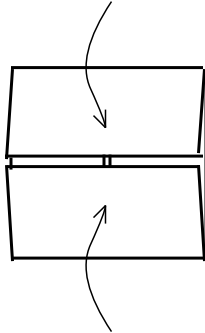

3

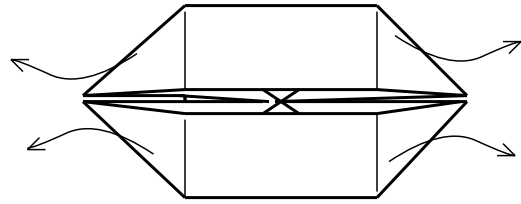

4

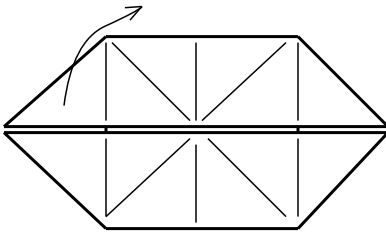

5

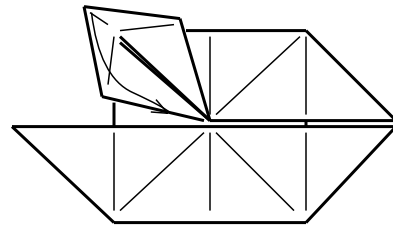

6

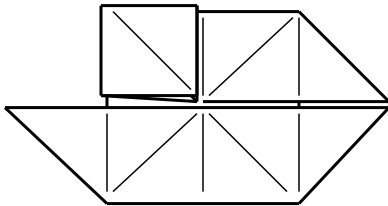

7

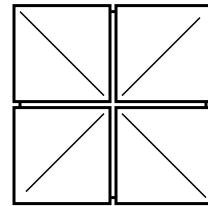

8

Reverse!

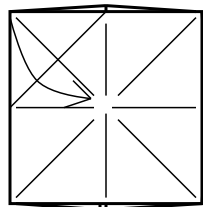

9

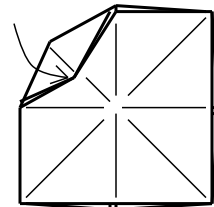

10

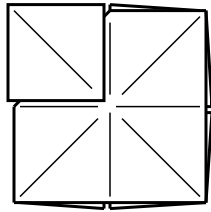

11

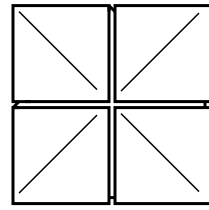

12

Reverse!

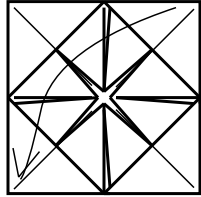

13

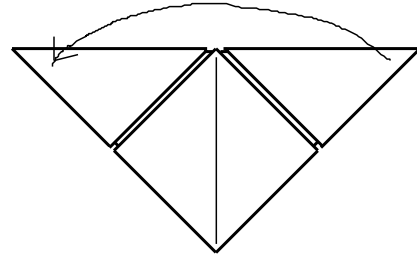

14

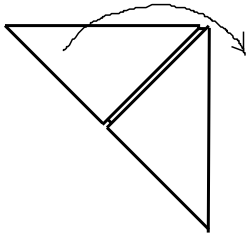

15

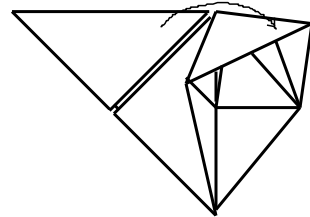

16

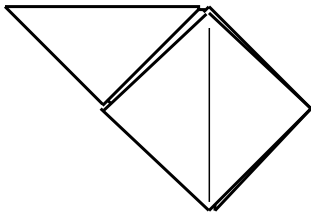

17

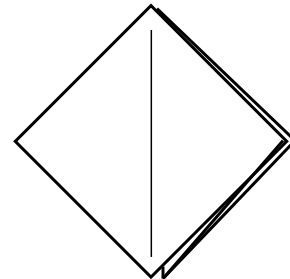

18

See from this angle.

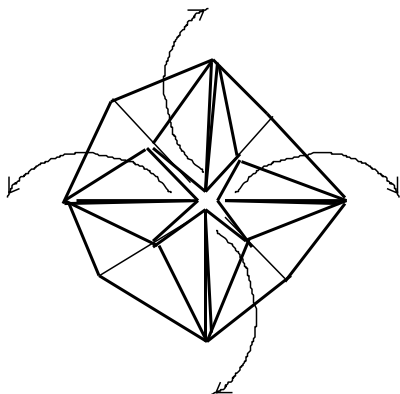

Pull out four corners.

19

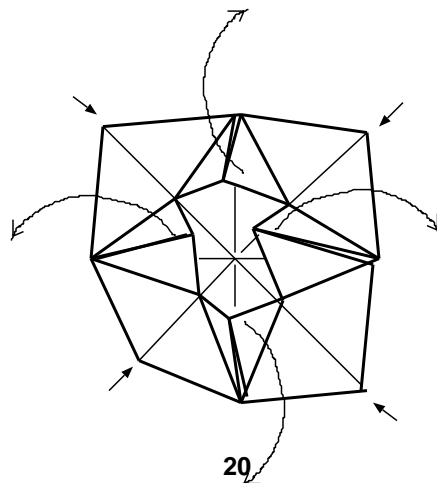

20

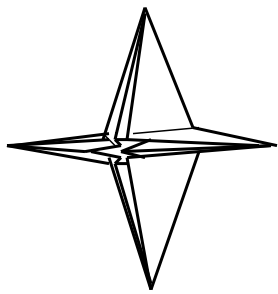

21

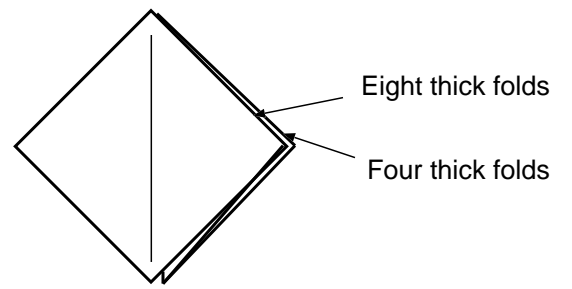

22

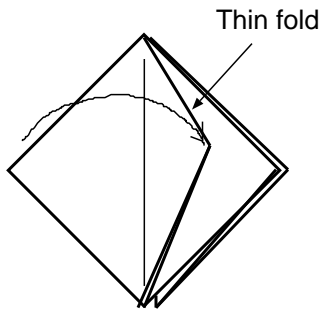

23

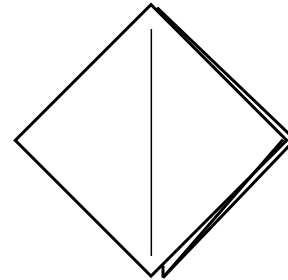

24

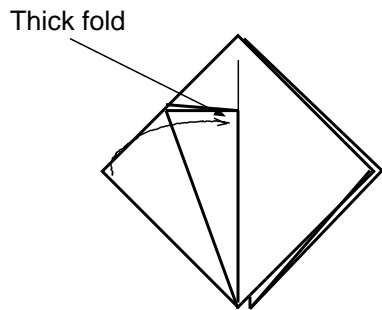

25

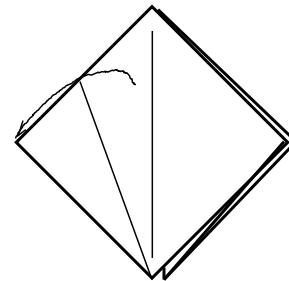

26

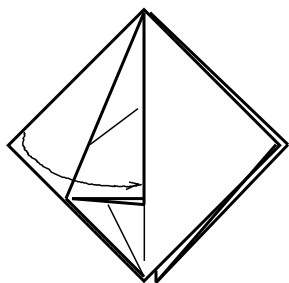

27

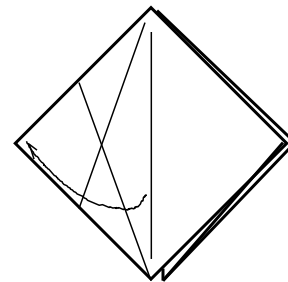

28

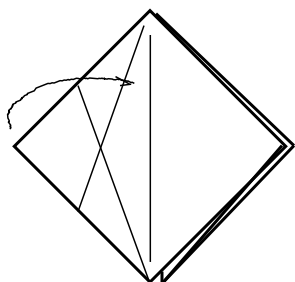

29

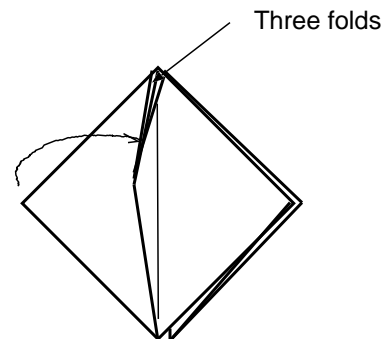

30

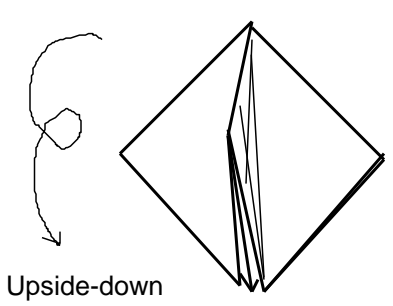

31

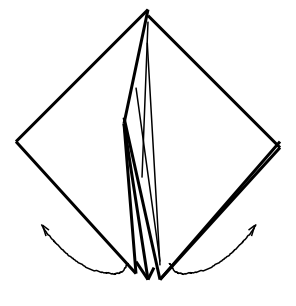

32

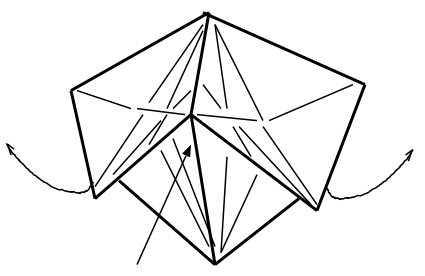

Smash!

33

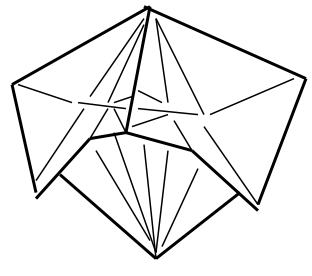

34

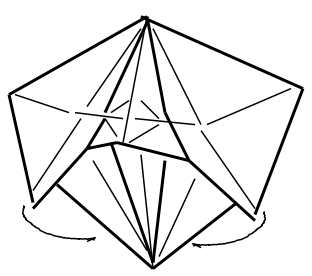

35

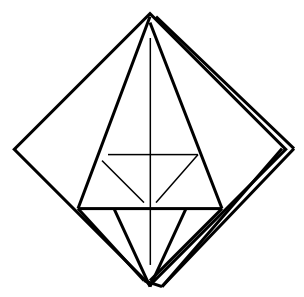

36

Repeat 25-36 three times.

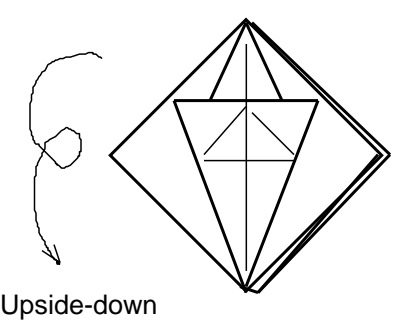

Upside-down

37

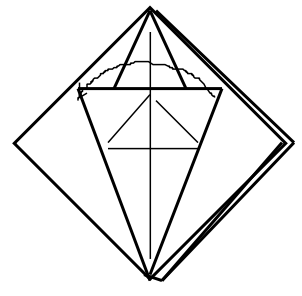

38

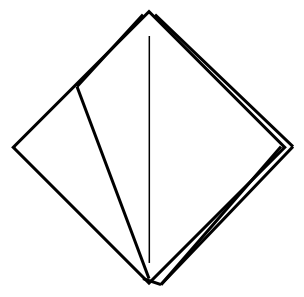

39

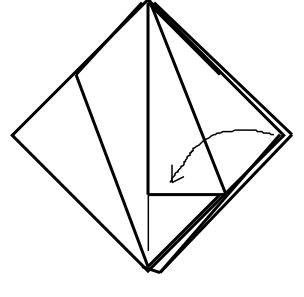

40

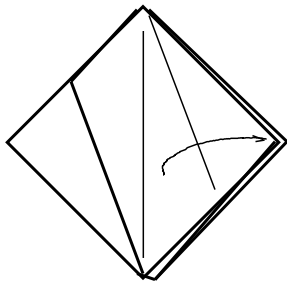

41

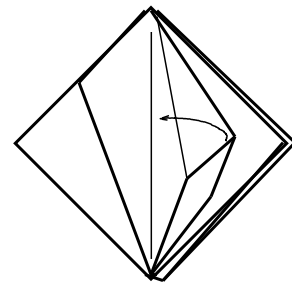

42

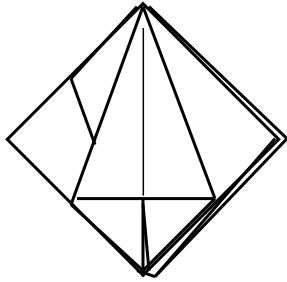

43

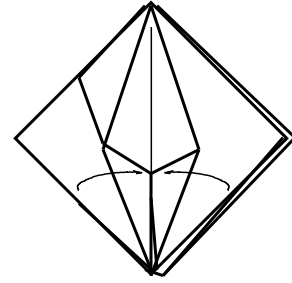

44

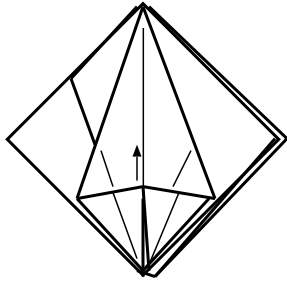

45

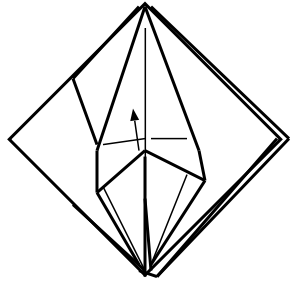

46

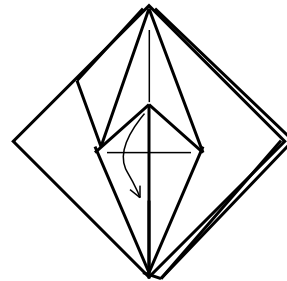

47

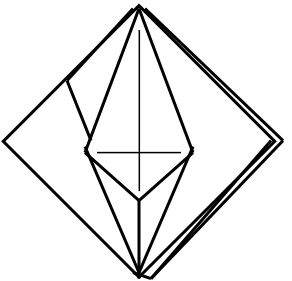

48

Repeat 40-48 seven times.

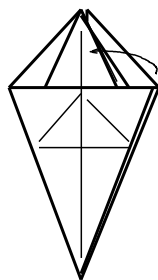

49

Three folds

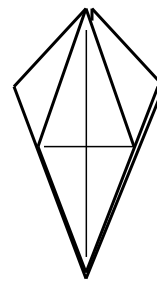

50

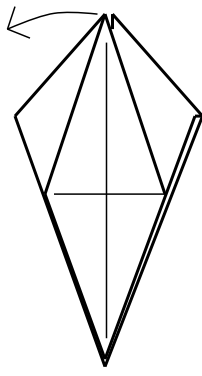

51

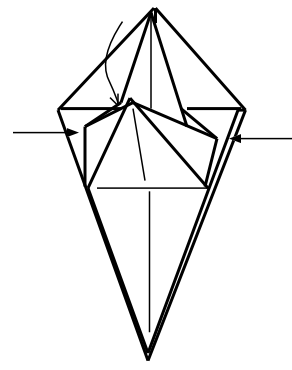

52

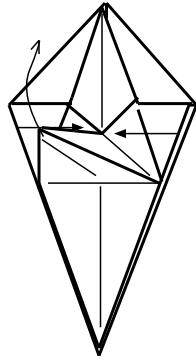

53

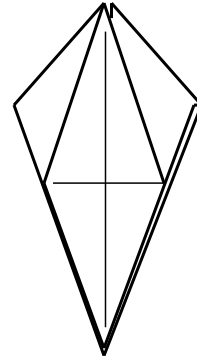

54

Repeat 51-54 three times.

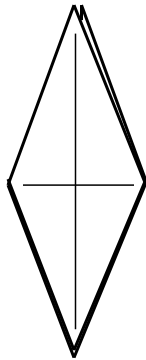

55

Finish!